

X Series Filter Skids

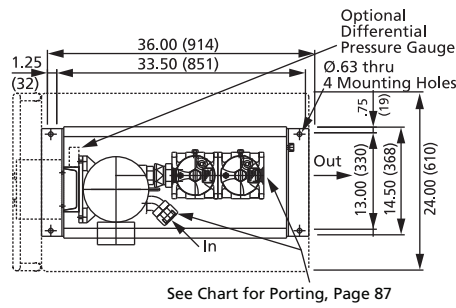

See Chart for Porting, Page 87

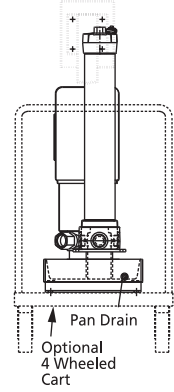
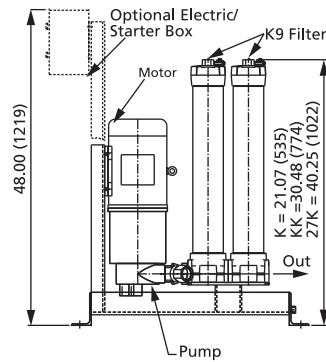

Dual K9 Filter Version (Series X4, X5 and X6)

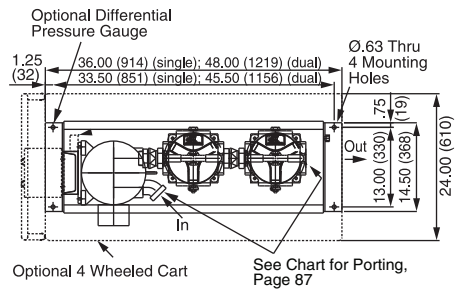

Optional 4 Wheeled Cart

See Chart for Porting, Page 87

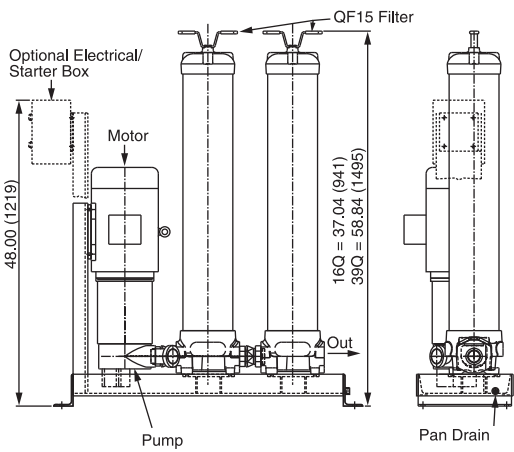

Pan Drain

Dual QF15 Filter Version (Series X4, X5 and X6)

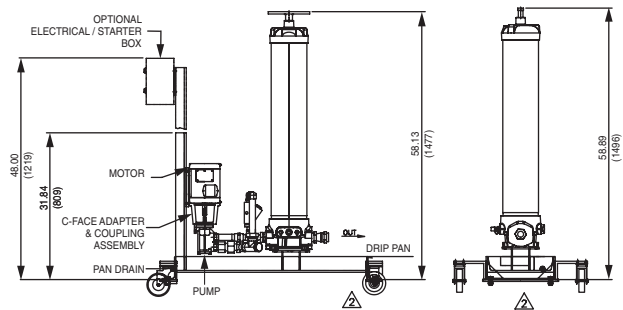
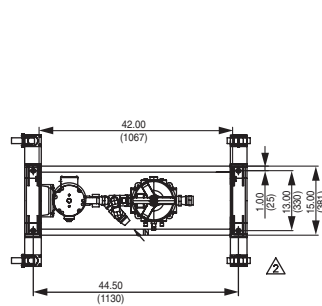

Series X7

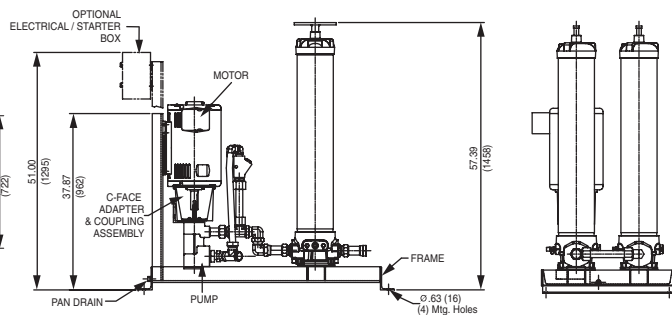
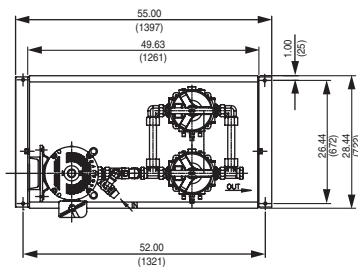

Series X8

Metric dimensions in ().

X Series Filter Skids

Model Number Selection

How to Build a Valid Model Number for a Schroeder X Series Filter Skid:

BOX 1	BOX 2	BOX 3	BOX 4	BOX 5	BOX 6	BOX 7	BOX 8	BOX 9	BOX 10	BOX 11	BOX 12

Example: NOTE: One option per box

BOX 1	BOX 2	BOX 3	BOX 4	BOX 5	BOX 6	BOX 7	BOX 8	BOX 9	BOX 10	BOX 11	BOX 12
X1	09	K92K	B	B	B	N	N	A	G	N	N

Skid Series	Flow (gpm)	Filter Designation					Element Media 1st Filter	Element Media 2nd Filter	Seal Material
		K9 Filter		3K	QF15 Filter				
		1K	2K	3K	16Q	39Q			
X1	09	1K	2K	3K			A = Z1 (K or Q) B = Z3 (K or Q) C = Z5 (K or Q) D = Z10 (K or Q) E = Z25 (K or Q) F = QCLQFZ1 G = QCLQFZ3 H = QCLQFZ5 J = QCLQFZ10 L = QCLQFZ25 M = QPMLZ1 P = QPMLZ3 R = QPMLZ5 S = QPMLZ10 T = QPMLZ25 W = W	N = NA A = Z1 (K or Q) B = Z3 (K or Q) C = Z5 (K or Q) D = Z10 (K or Q) E = Z25 (K or Q) F = QCLQFZ1 G = QCLQFZ3 H = QCLQFZ5 J = QCLQFZ10 L = QCLQFZ25 M = QPMLZ1 P = QPMLZ3 R = QPMLZ5 S = QPMLZ10 T = QPMLZ25 W = W	B = Buna (Standard) H = EPR V = Viton
	17	1K	2K	3K	1Q				
	37	1K	2K	3K	1Q	3Q			
	82			3K	1Q	3Q			
X2	09	1K	2K	3K					
	17		2K	3K	1Q				
	37			3K		3Q			
	82					3Q			
X3	09	1K	2K	3K	1Q	3Q			
	17		2K	3K	1Q	3Q			
	37			3K		3Q			
X4	09	1K	2K	3K					
	17	1K	2K	3K	1Q				
	37	1K	2K	3K	1Q	3Q			
	82			3K	1Q	3Q			
X5	09	1K	2K	3K					
	17		2K	3K	1Q				
	37			3K		3Q			
	82					3Q			
X6	09	1K	2K	3K	1Q	3Q			
	17		2K	3K	1Q	3Q			
	37			3K		3Q			
X7	06					3Q			
X8	30						3Q		

BOX 7	BOX 8	BOX 9	BOX 10	BOX 11	BOX 12
Power A = 115 VAC 1.5 hp (Available only with 109, 209, and 309) N = 230/460 VAC 3 PH. E = 575 VA 3 PH.	Motor Frame N = TEFC W = Washdown (NEMA Design B)	Starter Control Options N = None A = 230 VAC B = 460 VAC C = 230 VAC (with VFD) D = 460 VAC (with VFD) E = 575 VAC F = 575 VAC (with VFD)	Dirt Alarm N = Cartridge in Cap (Standard) G = Differential Pressure Gauge M = MS11 Electric Cartridge C = Differential Pressure Gauge with Electric Switch	Vacuum Gauge N = None V = Vacuum Gauge	Miscellaneous Options N = None S = Suction Strainer C = Mobile B = Continuous Bleed P = Particle Counter

Notes:

- Box 1: Z1 media not offered for use in 500 to 2000 SUS filtration skids. Contact factory for specific applications. (X2, X5)
Z1 and Z3 media not offered for use in 2000 to 5000 SUS filtration skids. Contact factory for specific applications. (X3, X6)
- Boxes 4 & 5: Z1 media not offered for use in 500 to 2000 SUS filtration skids. Contact factory for specific applications.
Z1 and Z3 media not offered for use in 2000 to 5000 SUS filtration skids. Contact factory for specific applications.
All elements are singular construction (no stacked elements).
QPML and QCLZ coreless elements only available in the QF15 housing.
X7 and X8 only available with options D and E.
- Boxes 9 and 10: Motor starter control option – C-series, non-disconnect shut-off, “motor on” light, electrical indicator “change element” light, and type 4x wash down enclosure.
VFD control option – same as above but with enclosed variable frequency drive control and larger metal NEMA enclosure. (Applies to M and C in Box 10)
- Box 12: Continuous bleed option – to eliminate filter air buildup in continuously aerated systems.
Includes cap vent port, valve, and return line. (B)
X7 and X8 not available with mobile (4-wheeled cart) option.
Suction strainer standard on X7 and X8
- Box 7: 115 VAC power option includes switch, 10' cord, and plug. For 1.5 hp motors only.
575 will be built to CSA standards. (E)
X7 and X8 only available with 230/460 VAC 3 phase motor.



- TCM
- TCM-FC
- TSU
- TMU
- TPM
- TIM
- TMS
- CTU
- TWS-C
- ET-100-6
- HMG 3000
- EPK
- HTB
- GS
- Trouble Check Plus
- Test Points
- Adapters
- Hose Joiners
- Microflex Hose
- Pressure Limiters
- Pressure Gauges
- Test Kits
- Probalizer
- Filtration Station
- MFS, MFD
- AMS, AMD
- KLS, KLD
- AKS, AKD
- KLC
- X Series**
- MTS
- HFS
- SVD
- TDS-A
- TDS-E
- IXU
- Appendix

X Series Filter Skids

Description

Schroeder's new X Series filtration skids are compact, self-contained filtration systems equipped with high efficiency, high capacity elements capable of removing particulate contamination and/or water quickly and economically. They supplement in-line filters whenever the existing filtration is incapable of obtaining the desired ISO cleanliness level.

It is not uncommon for viscosity to be overlooked when specifying an off-line filtration unit. The results of this oversight can severely affect system efficiency and longevity, and render the filtration system useless when high viscosity fluid causes the filter to be in constant bypass. Schroeder considers maximum fluid viscosity, (at the minimum operating temperature) in conjunction with flow to properly size the pump and motor.

Standard X Series skids (X1 through X6) include a hydraulic pump, electric motor, and either a single or dual K9 or QF15 housing. Many different component combinations provide the flexibility to match specific system viscosity, flow, and cleanliness requirements. Multiple housing lengths give the option of adding additional dirt holding capacity.

Schroeder's high viscosity X Series skids (X7 and X8) are designed to handle fluids that have a viscosity as high as 25,000 SUS. The skids have 39" long QF15 filters to efficiently clean the viscous fluids. The filters have a high dirt-holding capacity, capable of holding almost 1000 grams of dirt depending on the element. X7 and X8 skids include a pump, motor, QF15 filter, suction strainer, and dirt indicator. Various options can account for specific user needs.

Skid Selection

Series	Viscosity Range	Filter Housing(s)	Maximum Flow
X1	150 - 500 SUS	(1) QF15 or K9	82 gpm (310 L/min)
X2	500 - 2000 SUS	(1) QF15 or K9	82 gpm (310 L/min)
X3	2000 - 5000 SUS	(1) QF15 or K9	37 gpm (140 L/min)
X4	150 - 500 SUS	(2) QF15 or K9 in series	82 gpm (310 L/min)
X5	500 - 2000 SUS	(2) QF15 or K9 in series	82 gpm (310 L/min)
X6	2000 - 5000 SUS	(2) QF15 or K9 in series	37 gpm (140 L/min)
X7	100 - 25,000 SUS	(1) QF15	6 gpm (23 L/min)
X8	100 - 25,000 SUS	(2) QF15 in parallel	30 gpm (114 L/min)

Specifications

Flow Rating:	Up to 82 gpm (310 L/min)
Temp. Range:	0°F to 180°F (-17°C to 82°C)
Bypass Valve Setting:	50 psi (3.5 bar) for skid series X1, X2, X3, X4, X5, X7, and X8 40 psi (2.8 bar) for skid series X6
Fluid Viscosity:	Up to 25,000 SUS (see Skid Selection; previous page)
Compatibility:	All petroleum based hydraulic fluids. Contact Schroeder for use with other fluids, including ester and skydrol.
Pump:	X1-X6: Continuous duty gear pump with integral 150 psi relief. Flow dependent on skid series and motor. Refer to table below. X7-X8: Positive displacement rotary screw pumps
Motor:	Horsepower dependent on skid series and flow. Refer to table below.
Porting:	Dependent on flow. Refer to table below.

Pump and Motor Data

Skid Series	Flow (gpm)	Motor (hp)	Skid Series	Flow (gpm)	Motor (hp)
X1	09	1.5	X5	09	2
	17	3		17	5
	37	5		37	10
	82	10		82	15
X2	09	1.5	X6	09	2
	17	3		17	5
	37	5		37	10
	82	10	X7	06	2
X3	09	1.5	X8	30	15
	17	5			
	37	10			
X4	09	2			
	17	3			
	37	5			
	82	10			

X Series Filter Skids

Flow (gpm)	Inlet Port Sizes	Outlet Port Sizes with K9 & MK9 Filters	Outlet Port Sizes with QF15 Filters
06	1" JIC	N/A	1.625-12UN-2B SAE O-Ring Boss
09	1.625-12UN-2B SAE O-Ring Boss	1.312-12UN-2B SAE O-Ring Boss	1.625-12UN-2B SAE O-Ring Boss
17	1.875-12UN-2B SAE O-Ring Boss	1.625-12UN-2B SAE O-Ring Boss	1.625-12UN-2B SAE O-Ring Boss
30	2" JIC	N/A	1.625-12UN-2B SAE O-Ring Boss
37	2" JIC	1.875-12UN-2B SAE O-Ring Boss	1.875-12UN-2B SAE O-Ring Boss
82	2" JIC	1.875-12UN-2B SAE O-Ring Boss	2.500-12UN-2B SAE O-Ring Boss

Porting Data

Skid Series	Flow (gpm)	Weight (lb)*	Skid Series	Flow (gpm)	Weight (lb)*
X1	09	238-357	X5	09	301-442
	17	300-504		17	396-684
	37	329-577		37	497-849
	82	476-705		82	947-1054
X2	09	238-357	X6	09	267-650
	17	311-504		17	370-659
	37	348-577		37	502-607
X3	09	238-479	X7	06	Contact factory
	17	340-580	X8	30	Contact factory
	37	461-566			
X4	09	372-442			
	17	353-662			
	37	398-791			
	82	551-904			

Weight Data

*Weight dependent on options chosen.

- Protects and extends the life of expensive components
- Minimizes downtime and maintenance costs
- Designed to handle high viscosity oils up to 25,000 SUS (see Skid Selection; previous page)
- Many component combinations and variable starter options allow the flexibility to match specific user needs
- Four wheel cart option provides product portability
- Integral drip pan with drain plug protects oil from spilling on ground
- Sample valves provided at filter base for fluid sampling
- Market leading Schroeder Excellement® synthetic filtering media provides for quick, efficient clean up with maximum element life
- Availability of all plastic, environmentally friendly, coreless elements for QF15 housings (X1-X6 only)

Features

- TCM
- TCM-FC
- TSU
- TMU
- TPM
- TIM
- TMS
- CTU
- TWS-C
- ET-100-6
- HMG 3000
- EPK
- HTB
- GS
- Trouble Check Plus
- Test Points
- Adapters
- Hose Joiners
- Microflex Hose
- Pressure Limiters
- Pressure Gauges
- Test Kits
- Probalizer
- Filtration Station
- MFS, MFD
- AMS, AMD
- KLS, KLD
- AKS, AKD
- KLC
- X Series**
- MTS
- HFS
- SVD
- TDS-A
- TDS-E
- IXU
- Appendix