

Triton Dehydration Station™

US Patent Pending

TDS-E

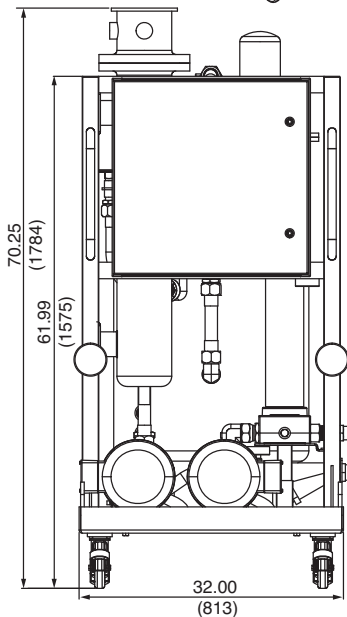
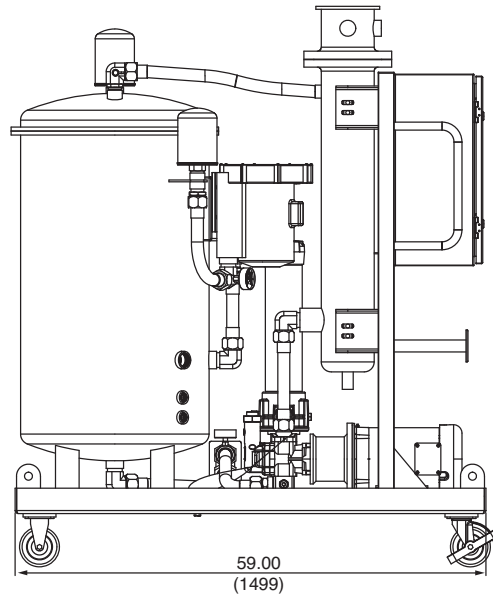
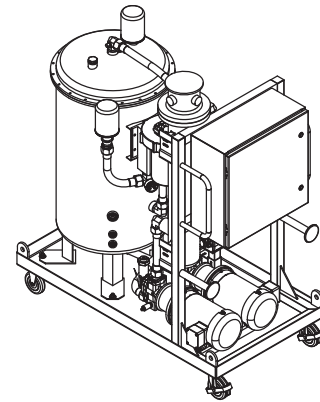
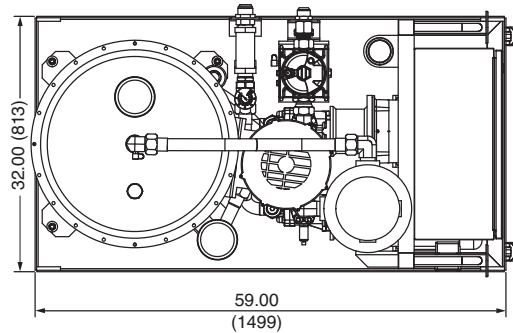
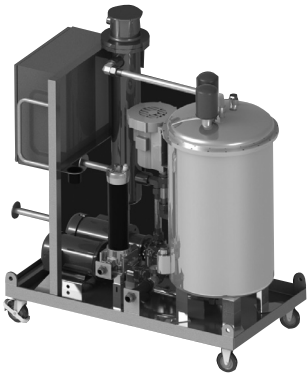

Metric dimensions in ().

Description

Water contamination in hydraulic systems can severely reduce the life of hydraulic systems and fluids. The Triton Dehydration Station is designed to eliminate 100% of free and up to 90% of dissolved water from small reservoirs, barrels, and gear boxes. Using a patent pending mass transfer process, the Triton Dehydration Station efficiently removes water and particulate contamination quickly in all environments. A proprietary design reduces aeration of free and entrained gases of returned fluid.

The TDS-E version handles a larger quantity of oil and higher flow rates than the TDS-A (see previous 2 pages). The TDS-E is recommended for up to 1000 gallon reservoirs with low water ingress rates or 400 gallon reservoirs with high water ingress rates.

Principle of Operation

The Triton Dehydration Station uses a new mass transfer dewatering technology. Ambient air is conditioned to increase its water holding capability before injecting to the reaction chamber. Fluid is equally distributed and cascaded down through reticulated media and the conditioned air stream. Water is transformed to water vapor and is expelled from the unit as a moist air stream. The relative humidity of the incoming fluid is continually monitored by an integral TestMate Water Sensor (TWS) and displayed real-time on the control panel.

Features

- High Dewatering Rates and particulate removal in one system
- Simple Controls
- Reduce fluid recycling cost
- No expensive vacuum pump to service and replace
- Patent Pending mass transfer technology uses ambient air to optimize and control dewatering rates
- Compact, efficient footprint
- Remove free and dissolved water
- Highly effective in low and high humidity elements
- Automatic air bleed on filter housing

Triton Dehydration Station™

US Patent Pending

Dimensions:	32" H x 59" L x 70.25" H
Dry Mass:	1000 lbs (453 kg)
Inlet Connections:	1-1/2" MJIC
Outlet Connections:	1-1/4" MJIC
Flow Rate:	900 gallons/hour
Inlet Pressure:	Atmospheric
Outlet Pressure:	to 125 psi (8.62 bar)
Fluid Service Temperature:	50° F to 175°F (10°C to 79°C)
Fluid Viscosity:	2000 SUS
Power Supply:	460 V/3/60 Hz, 7 amps 460 V/3/60 Hz, 22.5 amps w/heater 575 V/3/60 Hz, 5.5 amps 575 V/3/60 Hz, 18 amps w/heater
Attainable Water Content:	< 50 PPM
Relative Humidity Display:	Standard, 0-99% Range
Construction:	Base Frame: Carbon Steel Vessel: Stainless Steel Seals: Viton

Protection Class: NEMA-2

Media	Filter Rating	DHC (gm)	Media	Filter Rating	DHC (gm)
Z1	β 4.2 _(c) ≥1000	55	Z10	β 10 _(c) ≥1000	52
Z3	β 4.8 _(c) ≥1000	57	Z25	β 24 _(c) ≥1000	48
Z5	β 6.3 _(c) ≥1000	62			

How to Build a Valid Model Number for a Schroeder Triton Dehydration Station:

BOX 1	BOX 2	BOX 3	BOX 4	BOX 5	BOX 6	BOX 7	BOX 8
TDS							

Example: NOTE: One option per box

BOX 1	BOX 2	BOX 3	BOX 4	BOX 5	BOX 6	BOX 7	BOX 8
TDS	E	V	S	A	B	G01	

BOX 1 Dewatering Unit TDS	BOX 2 Flow Rate E = 15 gpm	BOX 3 Seals V = Viton	BOX 4 Mobility S = Stationary M = Caster Base	BOX 5 Voltage A = 460V/3/60 Hz (15 gpm) B = 575V/3/60 Hz (15 gpm)
BOX 6 Air Source B = Integral Blower	BOX 7 Media G01 = 1 μ Excellement® Media w/ GeoSeal™ G03 = 3 μ Excellement® Media w/ GeoSeal™ G05 = 5 μ Excellement® Media w/ GeoSeal™ G10 = 10 μ Excellement® Media w/ GeoSeal™ G25 = 25 μ Excellement® Media w/ GeoSeal™		BOX 8 Optional Heater H = 12500W Heater (15 gpm)	

Replacement Element Part Number (GeoSeal™ Elements)	Replacement Breather Part Number
KKGZ1 = 1μ Excellement® Z Media w/Standard GeoSeal™	MBF-3-M-P20 (both locations, all models)
KKGZ3 = 3μ Excellement® Z Media w/Standard GeoSeal™	
KKGZ5 = 5μ Excellement® Z Media w/Standard GeoSeal™	
KKGZ10 = 10μ Excellement® Z Media w/Standard GeoSeal™	
KKGZ25 = 25μ Excellement® Z Media w/Standard GeoSeal™	

Specifications

Element Performance

Model Number Selection

Replacement Elements

- TCM
- TCM-FC
- TSU
- TMU
- TPM
- TIM
- TMS
- CTU
- TWS-C
- ET-100-6
- HMG 3000
- EPK
- HTB
- GS
- Trouble Check Plus
- Test Points
- Adapters
- Hose Joiners
- Microflex Hose
- Pressure Limiters
- Pressure Gauges
- Test Kits
- Probalizer
- Filtration Station
- MFS, MFD
- AMS, AMD
- KLS, KLD
- AKS, AKD
- KLC
- X Series
- MTS
- HFS
- SVD
- TDS-A
- TDS-E**
- IXU
- Appendix