

Membrane Technology Systems

MTS

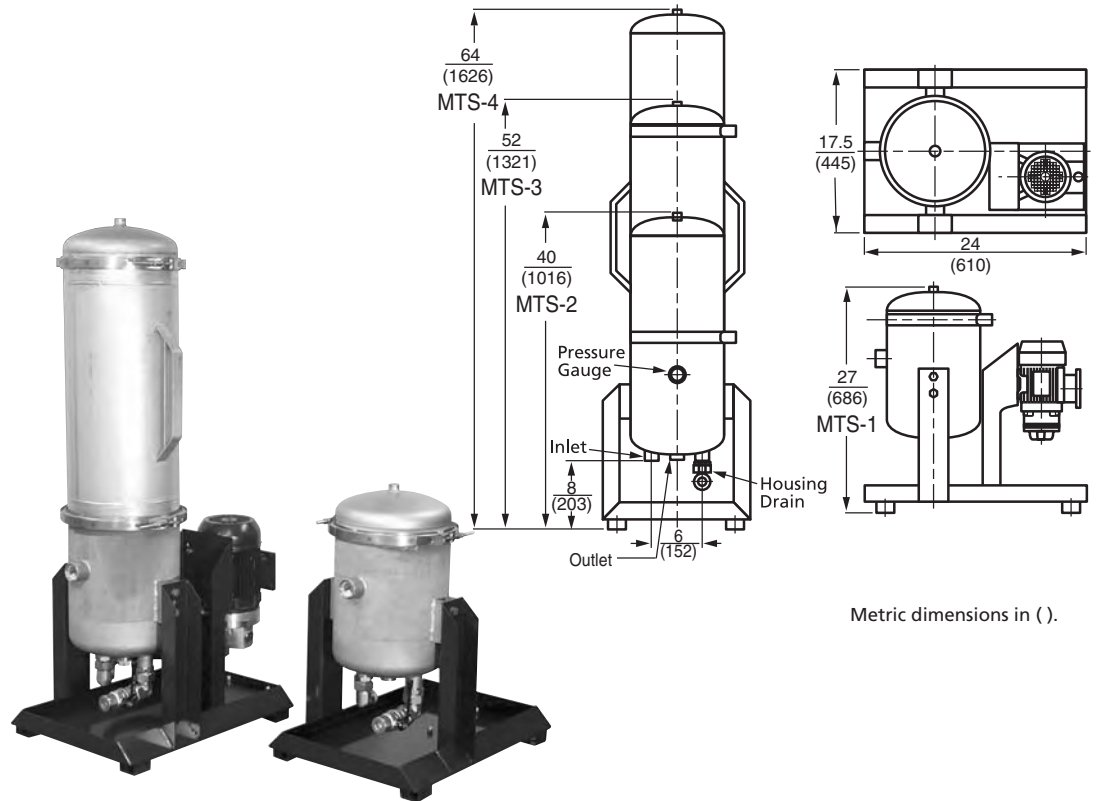

Metric dimensions in ().



Single Membrane Element

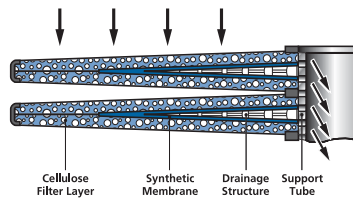

Element Cross Section

Description

The MTS from Schroeder is an off-line filtration system that features unique membrane elements constructed of stacked disks where dirt holding capacity is measured in pounds instead of grams, drastically reducing the amount of time required to clean up highly contaminated fluids. The abundant media surface area afforded by the stacked disk construction combined with the highly efficient membrane filtration give the MTS its very impressive dirt retention characteristics. The MTS can hold up to four filter elements and can be supplied as a stand-alone filter or with a pump and motor.

Features

- Effectively cleans hydraulic and cleaning fluids, lubricating oils, and coolants
- Provides excellent dirt removal efficiency, even in single pass filtration
- Available with pump and motor or can be utilized as an individual filter
- Included framework makes unit ready to install
- Easy to retrofit existing system
- Test points provided on all models
- Housing drain standard on all units

Applications

- Off-line filtration for hydraulic systems and test stands
- Bypass filtration
- Flushing and filling applications
- In-line auxiliary filtration

Membrane Technology Systems

	MTS-1	MTS-2	MTS-3	MTS-4
Number of Elements:	1	2	3	4
Contamination Retention Capacity:	1.1 lbs (500 g)	2.2 lbs (1000 g)	3.3 lbs (1500 g)	4.4 lbs (2000 g)
Filter Efficiency:	$\beta_x > 1000$	$\beta_x > 1000$	$\beta_x > 1000$	$\beta_x > 1000$
Permissible Δp Across the Element:	72.5 psi (5.0 bar)	72.5 psi (5.0 bar)	72.5 psi (5.0 bar)	72.5 psi (5.0 bar)
Weight Element:	6.6 lbs (2.99 kg)	13.2 lbs (5.99 kg)	19.8 lbs (8.98 kg)	26.4 lbs (11.97 kg)
Material of Filter Housing:	Stainless Steel	Stainless Steel	Stainless Steel	Stainless Steel
Capacity of Pressure Vessel:	5.25 gal (19.87 L)	10.50 gal (39.75 L)	15.75 gal (59.62 L)	20.5 gal (77.60 L)
Max Operating Pressure Filter Housing:	87 psi (6.0 bar)	87 psi (6.0 bar)	87 psi (6.0 bar)	87 psi (6.0 bar)
Material of Seals-Housing (standard):	Buna N	Buna N	Buna N	Buna N
Weight Housing:	25 lbs (11.34 kg)	33 lbs (14.97 kg)	53 lbs (24.04 kg)	62 lbs (28.12 kg)
Fluid Temperature:	15° to 175°F (-9.44° to 79.44°C)	15° to 175°F (-9.44° to 79.44°C)	15° to 175°F (-9.44° to 79.44°C)	15° to 175°F (-9.44° to 79.44°C)
Technical Details for Motor-Pumps Units:	5 gpm (18.93 L/min)	10 gpm (37.85 L/min)	15 gpm (56.78 L/min)	20 gpm (75.71 L/min)
Operating Pressure of the Pump:	65 psi (4.48 bar)	65 psi (4.48 bar)	65 psi (4.48 bar)	65 psi (4.48 bar)
Viscosity Range with Vane Pump (SUS):	75 to 2500	75 to 2500	75 to 2500	75 to 2500
Motor Capacity (watts) Vane Pump:	370 W	570 W	1500 W	1500W
Weight Vane Pump:	17 lbs (7.71 kg)	30 lbs (13.61 kg)	43 lbs (19.50 kg)	43 lbs (19.50 kg)
Material of Seals in Pumps (standard):	Buna N	Buna N	Buna N	Buna N
Vane Pump Connectors :	Model			
	MTS-1	1 1/16 -12UN (SAE 12)		
	MTS-2, 3, and 4	1 5/8 -12UN (SAE 20)		

Specifications

TCM
TCM-FC
TMU
TPM
TIM
CTU
TWS-C
ET-100-6
HMG 3000
EWC
EPK
HTB
GS
Trouble
Check Plus
Test Points
Adapters
Hose
Joiners

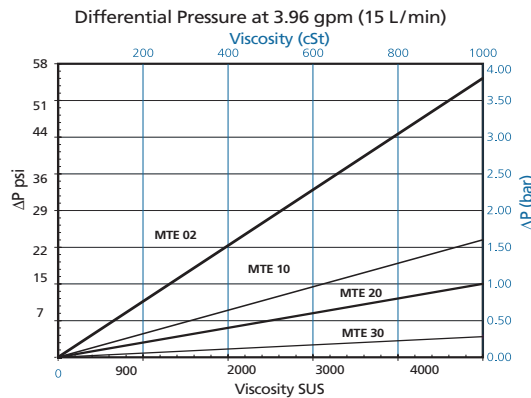

Element Pressure Drop

Microflex
Hose
Pressure
Limiters
Pressure
Gauges
Test Kits
Probalizer
Filtration
Station
MFS, MFD
AMS, AMD

Replacement Elements

MTE02 = 2 micron
MTE10 = 10 micron
MTE20 = 20 micron
MTE30 = 30 micron

Model	No. of Elements	Flow gpm (L/min)
MTS	1, 2, 3, 4	5 (19)
MTS	2, 3, 4	10 (38)
MTS	3, 4	15 (57)
MTS	4	20 (8)

Element Selection and Replacement Elements

KLS, KLD
AKS, AKD
KLC
X Series

MTS

HFS

SVD

TDS

IXU

Appendix

Membrane Technology Systems

MTS
continued

Sizing Off-line Filtration

The following calculations will help to approximate the attainable system cleanliness level when applying off-line filtration.

Step 1: Select the approximate contamination ingress rate from the chart. Quantitative investigations have yielded the following approximate figures.

Type of System	Contamination Ingression (µg/gal) Surroundings		
	Clean	Normal	Polluted
Closed circuit	1	3	5
Injection molding machine	3	6	9
Standard hydraulic system	6	9	12
Lubrication system	8	11	14
Mobile equipment	10	13	16
Heavy industrial press	14	18	22
Flushing test equipment	42	60	78

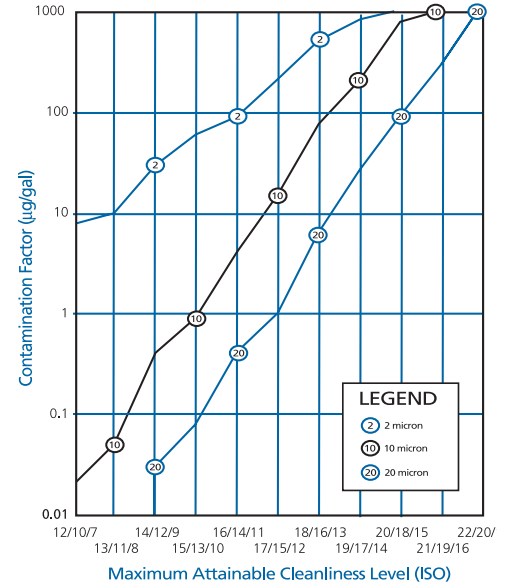

Step 2: Make the correction required for off-line filtration.

The contamination input selected above must be multiplied by the factor:

$$\text{Main System Flow Rate} / \text{Desired Off-line Flow Rate}$$

Note: Main system flow rate must be corrected for cycle time. For example, if the flow rate is 500 gpm, but only runs for 20% of the system cycle, the main system flow rate would be 100 gpm. (500 gpm X 20%)

This yields the expression:

$$\text{Contamination Factor} = \text{Contamination Input } (\mu\text{g/gal}) \times \frac{\text{Main System Flow Rate (gpm)}}{\text{Desired Off-line Flow Rate (gpm)}}$$

Calculate the contamination factor using this expression.

Step 3: Determine the attainable cleanliness level. Locate the calculated contamination factor on the y-axis of the attached graph. Go to the right to find the intersection point on the curve corresponding to the desired absolute filter micron rating. Read the resulting attainable cleanliness level on the x-axis. (In case of dynamic flow through the off-line filter, the attainable cleanliness level will be 2 to 3 times worse than indicated by the graph.)

Off-line Filtration Sizing Example

Type of System: Heavy industrial press

Surroundings: Normal

Main System Flow Rate: 150 gpm

Desired Off-line Flow Rate: 16 gpm (MTS-4)

Step 1: Using this criterion select the approximate contamination ingress rate from the chart above.

This yields a contamination input of 18 µg/gal based on a heavy industrial press with normal surroundings.

Step 2: Make the correction required for off-line filtration.

$$\text{Contamination Factor} = 18 \mu\text{g/gal} \times 150 \text{ gpm} / 20 \text{ gpm} = 135$$

Step 3: Determine the approximate attainable cleanliness level for each micron rating using the attached graph. If the attainable cleanliness level is not acceptable, the desired off-line flow rate should be increased. The approximate attainable levels for this example are as follows.

2 µm - ISO 17/15/12

20 µm - Between ISO 20/18/15 and ISO 21/19/16

Membrane Technology Systems

How to Build a Valid Model Number for a Schroeder Vacuum Dehydrator:

BOX 1	BOX 2	BOX 3	BOX 4	BOX 5	BOX 6	BOX 7	BOX 8
MTS							

Example: NOTE: One option per box

BOX 1	BOX 2	BOX 3	BOX 4	BOX 5	BOX 6	BOX 7	BOX 8
MTS	2	3	V	3	10	I	S

BOX 1	BOX 2	BOX 3	BOX 4	BOX 5
Membrane Technology System	Number of Elements	Pump Flow Rate* (must be ≤ No. of Elements)	Type of Pump	Motor
MTS	1 2 3 4	1 = 5 gpm 2 = 10 gpm 3 = 15 gpm 4 = 20 gpm X = no pump	V = Vane X = No Pump G = Gear Pump	1 = 115 VAC 3 = 230/460 VAC 3 PH 5 = 575 VAC 3 PH** X = No Motor***
BOX 6	BOX 7	BOX 8		
Absolute Rating of Element Media	Dirt Alarm	Options (may specify more than one)		
02 = 2 micron 10 = 10 micron 20 = 20 micron 30 = 30 micron	I = Integrated Pressure Gauge E = Electrical Diff. Pressure Gauge	S = SAE Adapters (BSPP connections are standard) V = Viton Seals		

Preferred order codes designate shorter lead times and faster delivery.

*See Element Selection Chart on page 83 for correlation between number of elements and flow. Other pumps available upon request.

**575 will be built to CSA standard.

***Motor is not included if pump is not specified.

Model Selection Number

TCM
TCM-FC
TMU
TPM
TIM
CTU
TWS-C
ET-100-6
HMG 3000
EWC
EPK
HTB
GS
Trouble Check Plus
Test Points
Adapters
Hose Joiners
Microflex Hose
Pressure Limiters
Pressure Gauges
Test Kits
Probalizer
Filtration Station
MFS, MFD
AMS, AMD
KLS, KLD
AKS, AKD
KLC
X Series
MTS
HFS
SVD
TDS
IXU
Appendix