

SECTION A-A

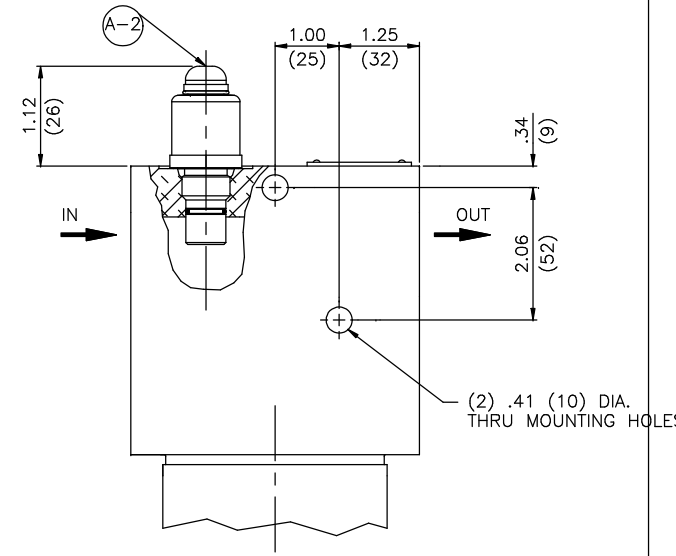

HEAD LOCATION

DIRT ALARM MECHANICAL CARTRIDGE
DIRT ALARM ELECTRICAL CARTRIDGE
MOUNTED IN SAME LOCATION

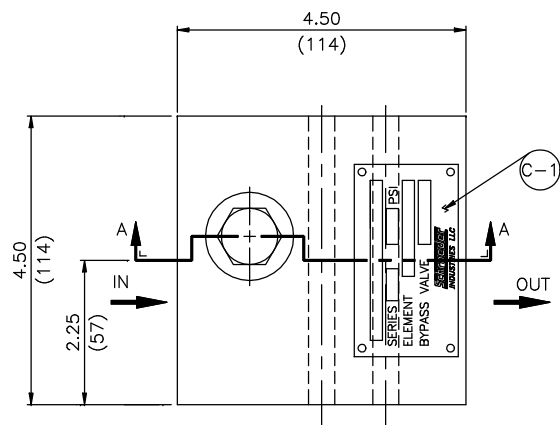
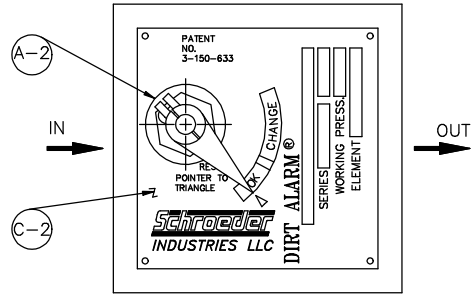

HEAD LOCATION

DIRT ALARM VISUAL
POINTER

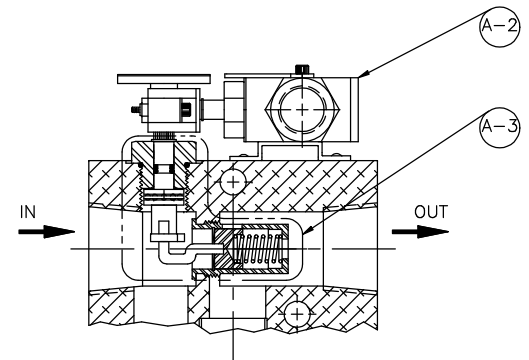

HEAD LOCATION

DIRT ALARM ELECTRICAL
CAM OPERATED

| | | | |
|------------|-----------------|---------|--------------------|
| MATERIAL | DEC. TOLERANCES | APP. | REV. CARD: 10546 |
| 2 PL. ± -- | CHK. M. SCHMITT | 5-1-02 | REV. DATE: 10/7/08 |
| 3 PL. ± -- | DWN. J. CADWELL | 4-24-02 | B/M |
| ANG. ± -- | DISK NO. | | P/N |

PARTS LIST FOR DF40 FILTER



| | |
|-------------|-------------|
| REV. | DRAWING NO. |
| 2 | D-8853 |
| SCALE: FULL | SHT. 1 OF 2 |

DF40-1C = 9.50 (241)
DF40-1CC = 14.38 (366)

