

# Kidney Loop Systems



**KLS**  
**KLD**



KLS



KLD

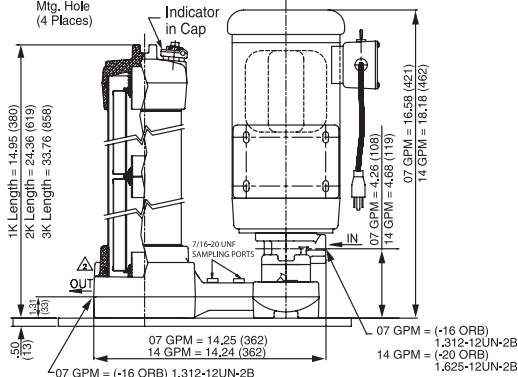
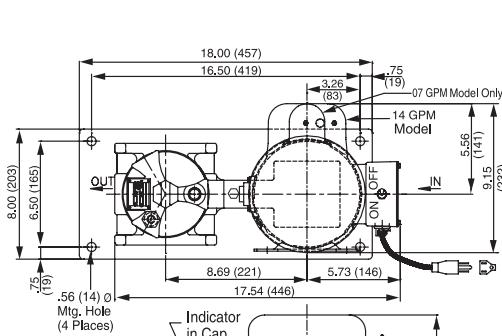

KLS

Metric dimensions in ( ).

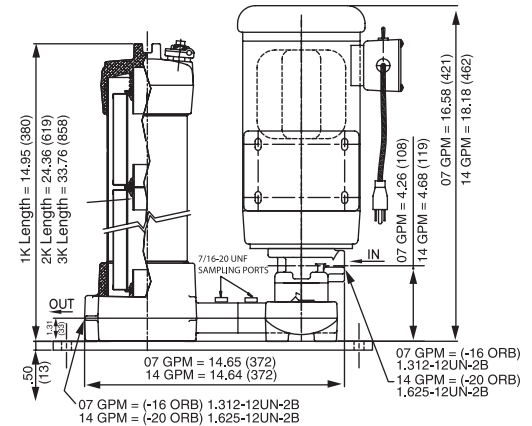
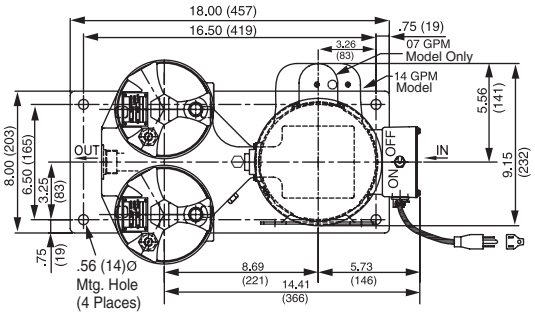

KLD

## Description

Schroeder's new off-line Kidney Loop System is a stationary version of the Mobile Filtration System. It is a compact, self-contained filtration system equipped with high efficiency, high capacity elements capable of removing particulate contamination and/or water quickly, conveniently and economically. This off-line system can be used to supplement in-line filters when adequate turnover cannot be achieved in the system. It is also ideal for water removal. Like the Mobile Filtration System, the new Kidney Loop System operates at a surprisingly low noise level. Its modular base eliminates hoses and fittings between components. The KLS single filtration unit can remove either water or particulate contamination. The KLD dual filtration unit can be used to remove both water and particulate contamination, or for staged particulate contaminant removal.

## Features

- Modular base eliminates connections between components and minimizes leakage
- Base-ported filter provides easy element service from the top cap
- Single, double and triple bowl length option allows the flexibility of additional dirt-holding capacity
- D5 Dirt Alarm® indicates when filter element needs changed
- Two 7/16 – 20 UNF sampling port included on all models



# Kidney Loop Systems

- Supplementing in-line filtration by system filters when adequate turnover cannot be attained
- Large volume systems requiring multiple filters in different locations
- Cleaning up a hydraulic system following component replacement
- Ideal location for water removal

<b>Flow Rating:</b>	7 gpm (26.5 L/min) max and 14 gpm (53.0 L/min) max
<b>Maximum Viscosity:</b>	1000 SUS (216 cSt) Higher viscosity version available. Contact factory for details.
<b>Operating Temperature:</b>	-20°F to 150°F (-29°C to 65°C)
<b>Bypass Valve Setting:</b>	Cracking: 30 psi (2 bar)
<b>Material:</b>	Manifold and cap: Cast aluminum Element case: Steel
<b>Compatibility:</b>	All petroleum based hydraulic fluid. Contact factory for use with other fluids.
<b>Motor:</b>	115 VAC single phase 3/4 hp (7 gpm) or 1-1/2 hp (14 gpm)
<b>Weight:</b>	KLS-1: 101 lb (45.9 kg) KLS-2: 112 lb (50.9 kg) KLS-3: 123 lb (55.9 kg) KLD-1: 117 lb (53.2 kg) KLD-2: 139 lb (63.2 kg) KLD-3: 161 lb (73.2 kg)

## How to Build a Valid Model Number for Schroeder Kidney Loop Systems:

BOX 1	BOX 2	BOX 3	BOX 4	BOX 5	BOX 6	BOX 7
<input type="text"/>	<input type="text"/>	<input type="text"/>	<input type="text"/>	<input type="text"/>	<input type="text"/>	<input type="text"/>

**Example:** NOTE: One option per box

BOX 1	BOX 2	BOX 3	BOX 4	BOX 5	BOX 6	BOX 7
KLS	1	18	E	E	V	07

BOX 1	BOX 2	BOX 3	BOX 4	BOX 5	BOX 6	BOX 7
<b>Model</b>	<b>No. of Elements*</b>	<b>Element Length</b>	<b>Element Media First Filter</b>	<b>Element Media Second Filter (KLD Only)****</b>	<b>Seal Material</b>	<b>Pump Size (gpm)</b>
KLS	1	09*	E**, Z, EWR***	E**, Z, EWR***	B = Buna N	07
KLD	2	18	plus 01, 03	plus 01, 03	V = Viton	14
	3	27	05 10, 25	05 10, 25		

Preferred order codes designate shorter lead times and faster delivery.

### Notes:

- \*When Box 2 equals 2 or 3, Box 3 must be 09. 09 is a preferred order code only when the number of elements is 3.
  - \*\*E media elements are only available in 03, 10 and 25 microns.
  - \*\*\*Water removal (W) elements are indicated by an "EWR" in the part number and are not followed by a 01, 03, 05, 10 or 25.
  - \*\*\*\*When KLD/KSD is ordered, the number of elements, element length, and seals will be identical for both filter housings.
- Contact factory if EPR seals are required.  
Contact factory for high viscosity version.

## Applications

## Specifications

- TCM
- TCM-FC
- TMU
- TPM
- TIM
- CTU
- TWS-C
- ET-100-6
- HMG 3000
- EWC
- EPK
- HTB
- GS
- Trouble Check Plus
- Test Points
- Adapters
- Hose Joiners
- Microflex Hose
- Pressure Limiters
- Pressure Gauges
- Test Kits
- Probalizer
- Filtration Station
- MFS, MFD
- AMS, AMD
- KLS, KLD**
- AKS, AKD
- KLC
- X Series
- MTS
- HFS
- SVD
- TDS
- IXU
- Appendix

## Model Number Selection