



# DRY WASH PURIFICATION SYSTEMS

#### Overview

GlyceRx™ is a chemically inert adsorptive media, designed for ease of use and landfill disposal.

This product is engineered for optimal purification efficiency, attracting the water soluble compounds, glycerin, soaps, glycerides and solids. The media will also adsorb excess methanol from the matrix although we recommend removal of the methanol PRIOR to the GlyceRx™ process. This ensures the longest bed life possible for the media

#### Fast Facts:

- **GlyceRx™** was designed specifically to meet the ASTM and EN specifications.
- **Ease of Use**  
GlyceRx™ is easy in, easy out.  
No more filter press, dusty loading or messy resins to handle while eliminating the inconsistencies of cellulose and other organic processes.
- **Feedstock Flexibility**  
Tests have show GlyceRx™ works equally well within a full range of biodiesel feedstock, from soy through yellow grease.
- **Low Cost Solution**  
GlyceRx™ has been designed to keep treatment costs low. For typical applications, treatment cost estimates are between \$0.03 and \$0.04 per gallon of biodiesel processed.



GlyceRx™ Media

#### GlyceRx Testing Results

Biodiesel Sample/Feedstock	Raw glycerin, soap and soluble (GSS) reported in ppm	Treated GSS reported in ppm	Influent total glyceride by GC method	Treated total glyceride by GC method
101/Soy	13960	<100	0.18%	0.01%
102/Choice White Grease	17923	<100	0.15%	0.03%
103/Yellow Grease	25140	145	0.29%	0.10%
104/Poultry Grade A	23105	167	0.24%	0.11%
105/Poultry Grade B	28230	212	0.40%	0.19%
107/Fancy Beef Tallow (FBT)	21087	172	0.21%	0.11%
108/Blend of 80% Poultry A and 20% Choice White	19814	174	0.20%	0.12%
109/Blend of 80% Poultry B and 20% Yellow Grease	27242	193	0.32%	0.14%

Notes: These are estimated usage rates based on lab and field tests of differing feed stocks. Results will vary with unique operation conditions and quality of feedstock.

## Features and Benefits

- Engineered for optimal purification efficiency
- Attracts water soluble compounds, glycerin, soaps, glycerides and solids
- Adsorbs excess methanol from the matrix  
*(recommend removal of Methanol prior to the GlyceRx™ process)*

## GlyceRx™ is available in the following forms:

- 50 pound bags, individual or pallet
- 2000 pound super sacks
- 400 pound plastic drums

### Model Number Selection

## Single Bags & Pallets

How to Build a Valid Model Number for Bag & Pallet Quantities of GlyceRx™:

BOX 1	BOX 2	BOX 3
GLY		

**Example:** Note: One option per box

BOX 1	BOX 2	BOX 3	
GLY	50	PB	= GLY50PB

BOX 1	BOX 2	BOX 3
<b>Model</b>	<b>Size</b>	<b>Packaging</b>
GLY	50 lb 400 lb 50 lb 200 lb	PB = Plastic Bag D = Plastic Drum PPB = Plastic Bag Pallet SS = Super Sack

### Cost Per Gallon Analysis

Part Number	Qty	Description	Gallons Treated	Cost/Gallon	Delivery
GLY-50-PB	1	50 lb plastic bag	4,500	0.05	
GLY-400-D	1	400 lb plastic drum	28,500	0.046	Direct Ship
GLY-50-PPB	20	50 lb plastic bag pallet	90,000	0.041	
GLY-2000-SS	1	2000 lb super sack	142,500	0.033	Direct Ship

NOTE:  
\*Based on Laboratory and Customer Results

# GlyceRx™ Treatment Towers

**GLY**

## Overview



Model no. of tower in photograph is:  
GLY - 4000

GlyceRx™ treatment vessels are available in several sizes and configurations to accommodate various operational capacities.

Vessels are designed to give the optimal contact time for the removal of polar fluids from biodiesel. They also feature epoxy lining to provide excellent corrosion protection. Each vessel has a drain fitting for removing liquid below outlet. The liquid collection system inside the vessel is designed to promote even flow distribution and thus, efficient adsorbent utilization.

Each Treatment Tower is capable of purifying in the volumes as shown in the table below. Purification times can be shortened and production levels increased by adding extra towers to your purification line.

## Features and Benefits

- Rugged carbon steel construction
- Easily retrofitted to your existing production line
- Designed for easy change outs
- Filter-free wash process
- Single-pass process
- Dry/waterless process
- Replacing GlyceRx™ media is fast and simple
- Built specifically to maximize performance of the GlyceRx™ purification process

## Specifications

	GLY - 200	GLY - 1800	GLY - 3200	GLY - 4000
Flow Rating	1.5-3 GPM	15-20 GPM	20-35 GPM	35-50 GPM
Daily Production Volumes (24 hrs)	2,160-4,320 gal	21,600-28,800	28,800-50,400	50,400-72,000
Final Filtration Method	Excellement® Beta1000 Media	Excellement® Beta1000 Media	Excellement® Beta1000 Media	Excellement® Beta1000 Media
Changeover Frequency	± 18,000 gallons	± 165,240 gallons	± 288,000 gallons	± 360,000 gallons
Estimated Annual Production	1,512,000	10,080,000	17,640,000	25,200,000
Max. Operating Pressure	50 PSIG	75 PSIG	75 PSIG	75 PSIG
Max. Operating Temperature	120° F	130° F	130° F	130° F

Note: These are estimated usage rates based on lab and field tests of differing feed stocks. Results will vary with unique operation conditions and quality of feedstock.

**GLY-200** is designed to hold 200 LBS of GlyceRx™ and is pivoted in the center for ease of discharge. This unit is designed for a maximum flow rate of 1.5–3 GPM. Overall dimensions are 30" wide x 80" tall. The diameter of the tower is 12". Maximum operating pressure is 50 PSIG. Maximum operating temperature is 120° F.

**GLY-1800** is an epoxy lined, 516-70 carbon steel vessel designed to hold up to 1830 LBS of GlyceRx™. Vessel access is a 14" x 18" top man way. Side man ways are available upon special order. Maximum operating pressure is 75 PSIG. Maximum operating temp is 130° F. "Overall dimensions are 79 1/2" tall x 38" diameter.

**GLY-3200** is an epoxy lined, 516-70 carbon steel vessel designed to hold up to 3200 LBS of GlyceRx™. Vessel access is a 14" x 18" top man way. Side man ways are available upon special order. Maximum operating pressure is 75 PSIG. Maximum operating temp is 130° F. "Overall dimensions are 93 1/2" tall x 46" diameter

**GLY-4000** is an epoxy lined, 516-70 carbon steel vessel designed to hold up to 4000 LBS of GlyceRx™. Vessel access is a 14" x 18" top man way. Side man ways are available upon special order. Maximum operating pressure is 75 PSIG. Maximum operating temp is 130° F. An optional side man way, for convenient access and cleaning, can be added to larger vessels. "Overall dimensions are 97" tall x 56" diameter.

## Model Number Selection

### How to Build a Valid Model Number for a GlyceRx™ Treatment Tower:

BOX 1	BOX 2	BOX 3
GLY		

**Example:** Note: One option per box

BOX 1	BOX 2	BOX 3	
GLY	1800	MW	= <b>GLY1800MW</b>

BOX 1	BOX 2	BOX 3
<b>Model</b>	<b>Size</b>	<b>Optional Manway</b>
GLY	200 1800 3200 4000	MW  *Not available on GLY-200

For help with this product, fill out "How to Build a Valid Model Code" and fax page to 724.318.1201, or send complete model code to [fueelfiltration@schroederindustries.com](mailto:fueelfiltration@schroederindustries.com).

## The Standard of Drywash Technology

Eco<sub>2</sub>Pure™ is a unique cellulose based, natural and sustainable composition of adsorbent technologies, specifically formulated for biodiesel purification from any feedstock. Eco<sub>2</sub>Pure's™ composition is designed to optimize purification efficiency and contamination removal, combined with increased flow enhancement characteristics.



Eco<sub>2</sub>Pure™ is designed to be a filter-free wash process with no consumables in the wash stage and the lowest cost drywash biodiesel purification method in existence today. Each pound of Eco<sub>2</sub>Pure™ is capable of purifying between 41-82 gals of biodiesel (Each kilogram of Eco<sub>2</sub>Pure™ is capable of purifying between 93-185 gallons of biodiesel\*).

Eco<sub>2</sub>Pure™ removes soaps, catalyst traces, residual methanol, moisture and other production residues from biodiesel, thereby assisting in the attainment of EN14214 & ASTM-D6751 quality standards.

Eco<sub>2</sub>Pure™ outperforms existing ion exchange resin technologies in terms of fuel quality, purification speed, as well as price, boasting the lowest purification costs on the market today\*. At \$0.03 cents per gallon\*\*, Eco<sub>2</sub>Pure™ can be used to replace or compliment your existing purification system, while allowing for a reduction in overall purification costs.

The frequency of re-bedding (replacing the spent media) will depend on the level of impurities in your biodiesel, the amount of biodiesel treated and the size of the Treatment Tower. So a single 120 lb (70 kg) Treatment Tower could only require re-bedding on average every 9,840 gallons. Loading is fast and simple, and once Eco<sub>2</sub>Pure™ is loaded, no other intervention is required. Once the Eco<sub>2</sub>Pure™ is bedded in the Treatment Tower, it automatically purifies the biodiesel in a single passage of flow.

Eco<sub>2</sub>Pure™ is available in tubs, drums or sacks for easy storage and transportation for the smaller producer, and available in bulk quantity for larger producers. For details of a stocking distributor near you, please contact us for more details.

A representative will work with you to determine the optimum utilization for your plant and to select the precise amount of Eco<sub>2</sub>Pure™ required, according to your process conditions.

\* Based on speed and price comparison of average resin prices on UK/USA mainland.

\*\*Eco<sub>2</sub>Pure™ life performance is determined by the initial starting quality of the crude biodiesel, base feed stocks, etc.

## Diagram of a Typical Biodiesel Production Process

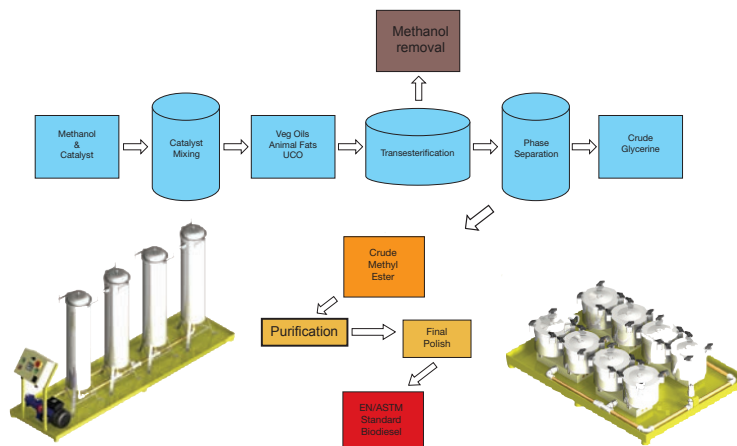

## Features and Benefits

- Continuous single pass purification
- Unmatched in soap removal
- Faster per kg flow than ion exchange
- Low capital expenses compared to batch adsorbants
- Sustainable media and no water required
- Spent Eco<sub>2</sub>Pure™ has a fuel value

Eco<sub>2</sub>Pure™ is packaged in convenient sized sacks for easy storage and transportation.

A representative will work with you to determine the optimum utilization for your plant, and to select the precise amount of Eco<sub>2</sub>Pure™ required, according to your process conditions.

For details of a stocking distributor near you, please visit [www.schroederbiofuels.com](http://www.schroederbiofuels.com).

**Model Code**

## Single Bags & Pallets

**How to Build a Valid Model Code for Bag & Pallet Quantities of Eco<sub>2</sub>Pure™:**

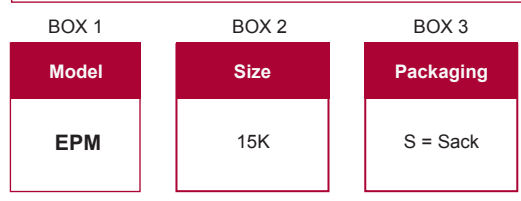

**Model Code**

## Direct Shipped Container Quantities

The Direct Shipped Container option offers competitive pricing to the end user. Please see cost per gallon analysis below.

**How to Build a Valid Model Code for Direct Shipped Container Quantities of Eco<sub>2</sub>Pure™:** *NOTE: One option per box*

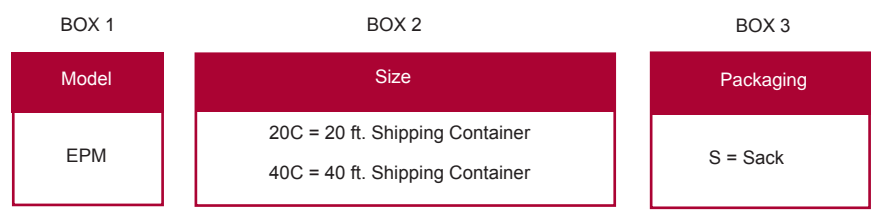

## Cost Per Gallon Analysis

Part Code	Min \$/gal*	Max \$/gal*
EPM-15K-S (Bag)	\$0.05	\$0.07
EPM-15K-S (Pallet)	\$0.04	\$0.05
EPM-20C-S	\$0.03	\$0.04
EPM-40C-S	\$0.02	\$0.03

\* Based on laboratory and customer results

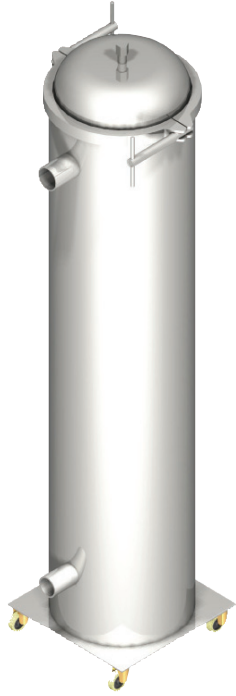

Eco<sub>2</sub>Pure™ Treatment Towers can be configured to suit all production volumes. Available with 70 kg Eco<sub>2</sub>Pure™ holding capacity, our systems are scalable to allow for increased volume production, allowing for continuous production and reduced purification times.

As the unwashed biodiesel enters the Eco<sub>2</sub>Pure™ Treatment Tower, it passes through a fixed bed of Eco<sub>2</sub>Pure™ purification media, ensuring the fuel is purified in a single pass, removing production residues, fuel contaminants and soaps. Flow rates need to be governed accordingly in order to ensure maximum removal of production residues and soap.

With each kilogram of Eco<sub>2</sub>Pure™ capable of purifying between 93-185 gallons of biodiesel, and each pound of Eco<sub>2</sub>Pure™ capable of purifying between 41-82 gals of biodiesel, the frequency of media replacement is kept to a minimum. All our products are CE rated, and have been pressure tested to meet international standards.

Each Treatment Tower is capable of purifying in the volumes as shown in the table below. Purification times can be shortened and production levels increased by adding extra towers to your purification line.

One tower capacity		Flow		
Capacity	gpm	gph	12hr day (g)	24 hr day (g)
120 lbs (70 kg)	2.0	120	1,440	2,880



## Features and Benefits

- Rugged stainless steel construction
- Easily retro-fitted to your existing production line
- Designed for easy change outs
- Filter-free wash process
- Single-pass process
- Dry/waterless process
- Replacing Eco<sub>2</sub>Pure™ media is fast and simple

Eco<sub>2</sub>Pure™ Treatment Towers are built specifically to maximize the performance of the Eco<sub>2</sub>Pure™ purification process.

## Model Code

### How to Build a Valid Model Code for a Schroeder EPTT:

BOX 1	BOX 2	BOX 3
<input type="text" value="EPTT"/>	<input type="text"/>	<input type="text"/>

Example: *NOTE: One option per box*

BOX 1	BOX 2	BOX 3	
<input type="text" value="EPTT"/>	<input type="text" value="70K"/>	<input type="text" value="W"/>	= EPTT70KW

BOX 1	BOX 2	BOX 3
Model	Eco <sub>2</sub> Pure™ Media Capacity	Mounting
EPTT	70K = 120 lbs (70 kg)	W = Wheel Mounted B = Base Mounted

Fill out "How to Build a Valid Model Code" and fax page to 724.318.1201, or Visit [schroederindustries.com](http://schroederindustries.com) and send complete model code to Ask The Expert.

## Continuous Flow

Schroeder Fuel Filtrations' unique design configurations enable continuous flow during the purification process, thereby eliminating any downtime. Any number of Eco<sub>2</sub>Pure™ Treatment Towers can be built into system designs, complete with pump, control panel and safety features. Flow rates will be governed accordingly to suit the number of towers in operation.

## Single Flow

As the unwashed biodiesel enters the Eco<sub>2</sub>Pure™ Treatment Tower, the fuel is purified in a single pass. In the same passage of flow, the washed fuel passes through a long-life final polishing bank to allow for the removal of residual production residues and soaps.

Eco<sub>2</sub>Pure™ is scalable to any size.

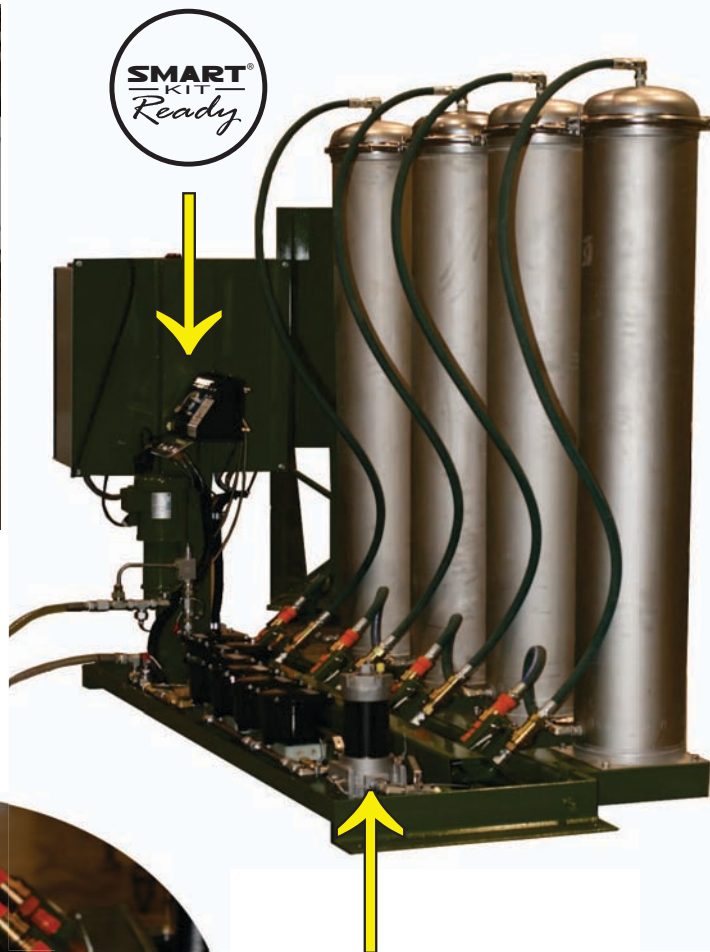

Excellement® Beta1000 Media

## Features and Benefits

- Easily retrofitted to your existing production process
- Low capital investment costs
- Filterless wash process-no consumables
- Can be configured for continuous flow applications
- Can replace or compliment your existing purification system
- Single-pass process
- Saves time... 2x faster than ion exchange resins
- Saves energy - no drying required
- Completely dry, waterless process
- Traceability with TestMate® Contamination Monitor (TCM) fitted

## Flow Comparison Chart: Eco<sub>2</sub>Pure™ vs Ion Exchange Resins

Purification Speed based on a SINGLE vessel \*

Eco <sub>2</sub> Pure™ Speed			gallons	gallons
Capacity* (kg)	gpm	gph	12hr day	24 hr day
120 lbs (70 kg)	2.0	120	1,440	2,880

Ion Exchange Resins Speed			gallons	gallons
Capacity* (kg)	gpm	gph	12hr day	24 hr day
110 lbs (50 kg)	0.7	40	480	960

### Cost Per Gallon Analysis:

\*Eco<sub>2</sub>Pure™ is one of lowest cost purification methods available in today's biodiesel market, and is priced as low as \$0.025 per gallon.

# Single Tower Eco<sub>2</sub>Pure™ Purification Systems

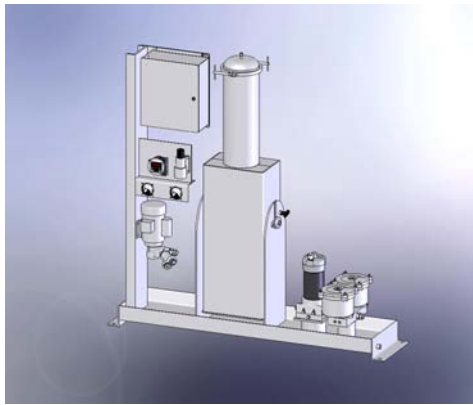

## Features and Benefits

- Rugged stainless steel construction
- Easily retrofitted to your existing production line
- Designed for easy change outs
- Single-pass process
- Dry/waterless process
- Replacing Eco<sub>2</sub>Pure™ media is fast and simple

The single tower Eco<sub>2</sub>Pure™ purification system combines the performance of the second generation dry wash media, Eco<sub>2</sub>Pure™, the filtration performance of Schroeder Industries' Excellement® media and 65 years of US manufactured quality. Systems include controls, safety considerations, online quality control options and operator feedback for ease of use.

### Single 70 kg Tower w/ Performance Filter

<b>Flow Rating:</b>	2 - 2.6 gpm (7.5 - 10 L/min)
<b>Daily Production Volumes (24 hrs):</b>	2,853 - 3,804 gals (10,800 - 14,400 L)
<b>Final Filtration Method:</b>	Excellement® Beta <sub>1000</sub> Media
<b>Changeover Frequency:</b>	± 7,925 gals (± 30,000 L)
<b>Estimated Annual Production:</b>	1,300,000 gal (4,921,035 L)

## Specifications

### How to Build a Valid Model Code for a Schroeder EWU:

BOX 1	BOX 2	BOX 3	BOX 4	BOX 5	BOX 6	BOX 7	= Contact Factory for Further Pricing Information
EWU							

Example: *NOTE: One option per box*

BOX 1	BOX 2	BOX 3	BOX 4	BOX 5	BOX 6	BOX 7	= EWU170K2W1WQ0
EWU	1	70K	2W	1	WQ	0	

## Model Code

BOX 1	BOX 2	BOX 3	BOX 4	BOX 5
Model	No. of Towers	Treatment Tower Capacity	Filtration Stages	Power Options
EWU	1	70K = 120 lbs (70 kg)	2W	1 = 110V 60Hz 2 = 220V 60Hz 1 phase 3 = 460/230V 3 phase 4 = 575V 5 = Air Diaphragm 6 = 110V 50Hz

BOX 6	BOX 7
<b>Connection</b> WQ = Hoses w/ Quick Disconnect 16M = 1" NPT 16V = 1" Cam Lock 16Q = 1" Quick Disconnects	<b>Quality Control</b> 0 = Blank Port 1 = TCM Particle Monitor 2 = TWS Water Sensor 3 = TCM & TWS

Notes:  
 1. Other sizes are available upon request  
 2. We can design, build and commission a purification system to suit your operation.  
 For more information please contact us to discuss your requirements.

Fill out "How to Build a Valid Model Code" and fax page to 724.318.1201, or visit [schroederindustries.com](http://schroederindustries.com) and send complete model code to Ask The Expert.

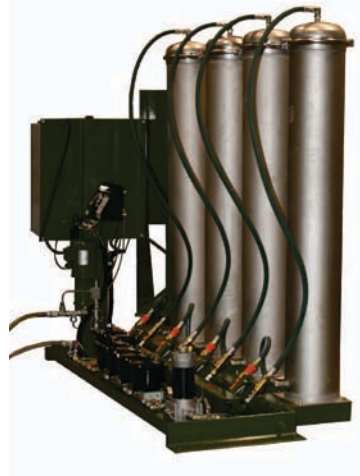

### Features and Benefits

- Rugged stainless steel construction
- Easily retrofitted to your existing production line
- Designed for easy change outs
- Single pass process
- Dry/waterless process
- Replacing Eco<sub>2</sub>Pure™ media is fast and simple

The multi tower Eco<sub>2</sub>Pure™ purification systems combine the performance of the second generation dry wash media, Eco<sub>2</sub>Pure™, the filtration performance of Schroeder Industries' Excelletem® media and 65 years of US manufactured quality. The world-class systems design includes automation, overrides, safety considerations, online quality control options and operator feedback for ease of use.

### Specifications

	Two 70 kg Tower w/ Performance Filter	Four 70 kg Tower w/ Performance Filter	Eight 70 kg Tower w/ Performance Filter
<b>Flow Rating:</b>	4 - 5.25 gpm (15 - 20 L/min)	7.5 - 10 gpm (30 - 40 L/min)	15 - 20 gpm (60 - 80 L/min)
<b>Daily Production Volumes (24 hrs):</b>	5,706 - 7,608 gals (21,600 - 28,800 L)	11,412 - 15,216 gals (43,200 - 57,600 L)	22,824 - 30,469 gals (86,400 - 115,340 L)
<b>Final Filtration Method:</b>	Excelletem® Beta <sub>1000</sub> Media	Excelletem® Beta <sub>1000</sub> Media	Excelletem® Beta <sub>1000</sub> Media
<b>Changeover Frequency:</b>	± 15,850 gals (± 60,000 L)	± 31,700 gals (± 120,000 L)	± 63,400 gals (± 240,000 L)
<b>Estimated Annual Production:</b>	2,700,000 gal (10,220,612 L)	5,330,000 gal (20,176,245 L)	10,700,000 gal (40,503,906 L)

### Model Code

**How to Build a Valid Model Code for a Schroeder EWU:**

BOX 1	BOX 2	BOX 3	BOX 4	BOX 5	BOX 6	BOX 7	= Contact Factory for Further Pricing Information
EWU							

Example: *NOTE: One option per box*

BOX 1	BOX 2	BOX 3	BOX 4	BOX 5	BOX 6	BOX 7	= EWU470K2W1WQ0
EWU	4	70K	2W	1	WQ	0	

Model	No. of Towers	Treatment Tower Capacity	Filtration Stages	Power Options
EWU	2 3 4 8	70K = 120 lbs (70 kg)	2W 3W	1 = 110V 60Hz 2 = 220V 60Hz 1 phase 3 = 460/230V 3 phase 4 = 575V 5 = Air Diaphragm 6 = 110V 50Hz

BOX 6	BOX 7
Connection	Quality Control
WQ = Hoses w/ Quick Disconnect 16M = 1" NPT 16V = 1" Cam Lock 16Q = 1" Quick Disconnects	0 = Blank Port 1 = TCM Particle Monitor 2 = TWS Water Sensor 3 = TCM & TWS

- Notes:
1. Other sizes are available upon request
  2. We can design, build and commission a purification system to suit your operation.

Fill out "How to Build a Valid Model Code" and fax page to 724.318.1201, or visit [schroederindustries.com](http://schroederindustries.com) and send complete model code to Ask The Expert.

**Filter Pads for EPTT Towers**

Each part number listed below includes a single filter pad.



Part Number	Description
BD-192	25 micron filter pad for EPTT-70K

# Life Monitoring & Quality Control

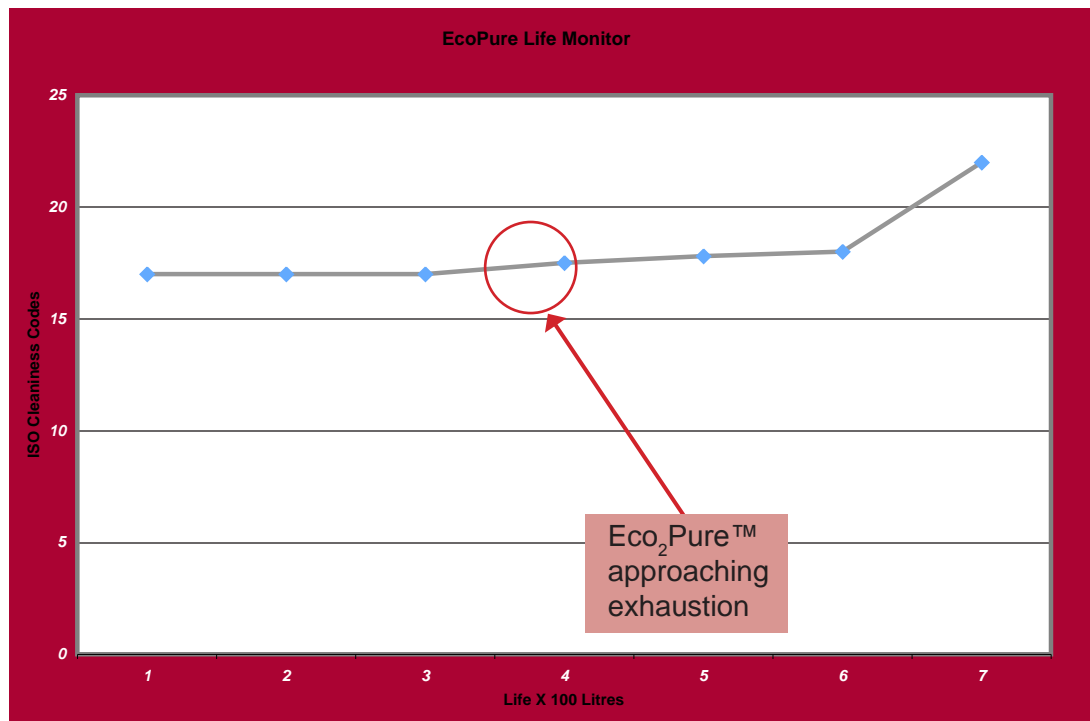

## Eco<sub>2</sub>Pure™ Monitoring Using TCM Particle Monitor

Using the TCM online particle monitor, biodiesel producers can effectively monitor the residual life of Eco<sub>2</sub>Pure™. The particle counts increase as the media approaches exhaustion, allowing for adequate notification for Eco<sub>2</sub>Pure™ rebedding. This is an excellent way of ensuring that ONLY quality fuel is produced, and eliminates the possibility of downstream migration of production residues, moisture and soaps. This also allows for trend indication for batch/continuous process control. Live cleanliness data can be viewed on your PC screen and archived in real-time.



TCM Particle Monitor → Transfer live data to PC for evaluation/archiving → Print off reports for your quality control program.

**“Putting You in Control of Your Biodiesel Quality”**

# Eco<sub>2</sub>Pure™ Performance Data

Parameter	Test method	Units	Europe	USA	Rape Seed M.E		WVO	Methyl Ester
			EN14214	ASTM D6751	Before	After	Before	After
<b>Soap</b>	<b>None</b>	<b>None</b>	<b>None</b>	<b>None</b>	<b>650</b>	<b>0</b>	<b>1890</b>	<b>0</b>
Free Glycerol	EN14105	% mass	0.2 max	0.2 max	0.052	0.005	0.0065	0.002
Total Glycerol %	EN14105	% mass	0.25 max	0.24 max	0.23	0.169	0.215	0.139
Flash Point °C	ISO2719	°C	120 min	130 min	90	140	105	158
Group Metals I (Na+K)		mg/kg	5 max	5 max	51	0	66	0
Group Metals II (Ca+Mg)		mg/kg	5 max	5 max	5	0	7	0
Oxidation Stability @ 110°C	EN14112	Hours	6 mins	3 mins	0.63	2.27	0.5	4.3
Water	EN ISO 12937	mg/kg	500 max	500 max	400	363	1400	420
Sulfated Ash	EN ISO 3987	mass %	0.02 max	0.02 max	0.056	0	0.09	0.002
Methanol Content %	EN14110	mass %	0.2 max		0.19	0.009	0.36	0.0019
Acid Value mg/KOH/g	EN1404	mg KOH/g	0.5 max	0.8 max	0.5	0.09	0.6	0.3
Total Contamination	EN12662	mg/kg	24 max	*	29	4	35	6
Appearance	None	None	None	None	Cloudy	Clear Bright	Cloudy	Clear Bright

\* Combined water and contamination test under ASTM D6759

# Frequently Asked Questions

## **What makes GlyceRx™ Eco<sub>2</sub>Pure™ so unique?**

Eco<sub>2</sub>Pure™ is a natural and sustainable biodiesel purification media, and GlyceRx™ is a chemically inert adsorptive media, designed for ease of use and landfill disposal. Both media's boasts one of the lowest purification costs per liter/gallon on the market today. Eco<sub>2</sub>Pure™ is proven to assist in the attainment of EN/ASTM quality standards.

## **Are GlyceRx™ Eco<sub>2</sub>Pure™ similar to ion exchange resin?**

No, unlike ion exchange systems, GlyceRx™ and Eco<sub>2</sub>Pure™ are adsorbent technologies, which allow for removal of soaps, production residues, residual methanol and moisture from biodiesel.

## **Are GlyceRx™ and Eco<sub>2</sub>Pure™ Treatment Towers available loose?**

GlyceRx™ and Eco<sub>2</sub>Pure™ Treatment Towers are available loose for producers to configure as they like or as part of a system.

## **What is an Eco<sub>2</sub>Pure™ System?**

We do all the work for you. Pumps, control panels, safety features are all configured to achieve maximum media life, production throughput and fuel quality.

## **How do you know when the GlyceRx™ and Eco<sub>2</sub>Pure™ is exhausted?**

There are several ways to monitor remaining life:

- a) Pressure indication
- b) Flow measurement
- c) Particle counts

## **How much biodiesel will each pound of GlyceRx™ and Eco<sub>2</sub>Pure™ purify?**

Each pound of Eco<sub>2</sub>Pure™ will purify between 93-185 gallons of biodiesel. Each pound of GlyceRx™ will purify up to 90 gallons of biodiesel.

## **Can I increase my purification rate if I need to upscale?**

By adding extra Treatment Towers, you can increase your throughput. Treatment Towers are available in various sizes to suit all production volumes.

## **Do I require final polishing?**

Irrespective of the wash method you employ, final polishing is advisable to remove all traces of production residues, soaps and moisture prior to use.

## **Can you still offer traceability with the GlyceRx™ Eco<sub>2</sub>Pure™ system?**

Yes, a particle counter can be fitted to our systems to monitor fuel quality in real time.

## **How does the price of GlyceRx™ Eco<sub>2</sub>Pure™ compare to other wash methods?**

GlyceRx™ and Eco<sub>2</sub>Pure™ are one of the most competitively priced systems on the market today. Not only in terms of start-up costs, but also in terms of the cents per gallon cost.